



Laboratory for Fire Safety

Classification of the fire resistance in accordance with EN 13501-2:2023 of several linear joint seals in a flexible wall

Classification report

Report number YA 3198-1E-RA-001 dated 24 September 2024

Laboratory for Fire Safety

Classification of the fire resistance in accordance with EN 13501-2:2023 of several linear joint seals in a flexible wall

Classification report

Client	Soudal NV Everdongenlaan 18 2300 Turnhout Belgium
Prepared by	Peutz bv Lindenlaan 41 6584 AC Molenhoek Postbus 66 6585 ZH Mook The Netherlands
Product name	Linear joint seals in a flexible wall
Report number	YA 3198-1E-RA-001
Date of issue	24 September 2024
Reference	RO/RO//YA 3198-1E-RA-001
Representative	R.R.H. Okkersen, BSc.
Author	R.R.H. Okkersen, BSc. 0031 85 8228618 r.okkersen@peutz.nl



This classification report, containing 24 pages, can only be used and reproduced as an entity.

peutz bv, kloppsteen 4a, nl-5443 pw haps, +31 85 8228 600, info@peutz.nl, www.peutz.nl
kvk 12028033, all orders according to DNR 2011, member NLingenieurs, btw NL.004933837B01, ISO-9001:2015

mook – haps – zoetermeer – groningen – eindhoven – düsseldorf – dortmund – berlijn – leuven – parijs – lyon

Table of content

1 Introduction	4
2 Details of the classified system	5
2.1 General	5
2.2 Product description	5
3 Test reports and results in support of the classification	7
3.1 Used report	7
3.2 Report Y 3198-3E-RA-001	8
3.2.1 Test results	9
4 Classification and field of application	12
4.1 Reference of classification	12
4.2 Soudal ISOTAET and Soudaseal 211 joining flexible walls to rigid walls	12
4.3 Soudal ISOTAET joining flexible walls to rigid walls	16
4.4 Soudal ISOTAET and Soudaseal 211 joining flexible walls	18
4.5 Soudal ISOTAET joining flexible walls	22
5 Limitations	24

1 Introduction

This classification report defines the fire resistance classifications assigned to several linear joint seals in a flexible wall. The joint seals were tested in the Peutz Laboratory for Fire Safety in Haps according to the standard heating curve and in accordance with the procedures given in EN 13501-2:2023.

The joint seals were tested in one test in a wall consisting out of aerated concrete and 2 flexible walls on July 23, 2024.



For performing measurements, the Laboratory for Fire Safety of Peutz bv is recognized by the Dutch Accreditation Body RvA..

The RvA is member of the **EA MLA** (European Accreditation Organisation MultiLateral Agreement). www.european-accreditation.org

EA: "Certificates and reports issued by bodies accreditatie by MLA and MRA members are considered to have the same degree of credibility, and are accepted in MLA and MRA countries".

An overview of the sealants and foams that were used for the linear joint seals is given in Table 2.2.

t.2 *Materials used*

Type of material
Soudal ISOTAET
Soudaseal 211

3 Test reports and results in support of the classification

3.1 Used report

An overview of the used report is given in Table 3.1.

t3.1 Used report

Name of laboratory	Name of client	Report reference number and date	Used methods
Peutz bv	Soudal N.V.	Test report Y 3198-3E-RA-001 dated August 28, 2024	EN 1363-1:2020 EN 1366-4:2021

The client has stated that the provided report may be used for this classification report.

Details of the relevant linear joint seals with respect to this report are given in Paragraph 3.2. A brief description of the test results is given in Paragraph 3.2.1. For clarity, the numbering of the linear joint seals is taken over from the test report mentioned in Table 3.1. For a complete description and drawings of the test specimen see the test report mentioned in paragraph 3.1.

As stated in EN 13501-2:2023, failure of the integrity criteria is deemed to have occurred when "cracks or openings in excess of the given dimensions" occur. In the requirements for fire resistance tests on linear joint seals (EN 1366-4:2021) is stated that the gap gauges for determining the criterion integrity shall not be used. No visual openings arose during the tests so there is no influence on the classifications in this report.

3.2 Report Y 3198-3E-RA-001

The first layer of gypsum boards is mounted on each side of the metal stud profiles with a linear joint on both sides and on the top side. These 6 joints are sealed with Soudal ISOTAET, with a width 12.5 mm and a depth of 12.5 mm. After the sealant has been applied the second layer of gypsum boards is mounted on each side of the wall (with a joint in the middle of the flexible wall) closing of the joint filled with Soudal ISOTAET. The gypsum boards are fixed with plasterboard screws (3.5 x 35 mm) c.t.c. 200 mm. The joint of the flexible walls and the screws are finished with Gyproc JointFiller 45.

For seal 1, 2, 4 and 5 the edges are sealed with Soudaseal 211 in a triangular shape (10 x 10 x 14 mm). The linear joints 3 and 6 are not sealed after the second layer of gypsum boards are mounted.

An overview of the tested linear joint seal is given in Table 3.2.

t3.2 Details of the tested linear joint seals

Linear joint seal number	Orientation	Joint width (mm)	Details of the tested linear joint seals					
			Seal at the exposed face			Seal at the unexposed face		
			Type	Depth (mm)	Width (mm)	Type	Depth (mm)	Width (mm)
1	Vertical	14	Soudaseal 211	10	10	Soudaseal 211	10	10
2	Horizontal	14	Soudaseal 211	10	10	Soudaseal 211	10	10
3	Vertical	0	n.a.	n.a.	n.a.	n.a.	n.a.	n.a.
4	Vertical	14	Soudaseal 211	10	10	Soudaseal 211	10	10
5	Horizontal	14	Soudaseal 211	10	10	Soudaseal 211	10	10
6	Vertical	0	n.a.	n.a.	n.a.	n.a.	n.a.	n.a.

3.2.1 Test results

Soudaseal 211 on gypsum material and flexible wall (wall thickness 100 mm), vertical

The summary of the test results achieved with Soudaseal 211 applied on gypsum material/flexible wall in a vertical linear joint seal is shown in Table 3.3. Soudal ISOTAET is applied over 12.5 x 12.5 mm (width x depth) in the joint seal of the first layer of gypsum boards. The Soudaseal 211 is applied in a triangular shape (10 x 10 x 14 mm) on both sides (seal 1).

t3.3 Test results seal 1

Test method	Parameter	Sub-criterion	Result in minutes (linear joint seal no.1)
			Thickness flexible wall 100 mm
			Vertical
EN 1363-1:2020	Integrity (E)	– Cotton pad	120*
EN 1366-4:2021	Integrity (E)	– Sustained flaming > 10 seconds	120*
	Insulation (I)		120*

*The test was finished after 120 minutes in consultation with the client. After finishing the test, the criteria marked with a * where not reached yet.*

Soudaseal 211 on gypsum material and flexible wall (wall thickness 100 mm), horizontal

The summary of the test results achieved with Soudaseal 211 applied on gypsum material/flexible wall in a horizontal linear joint seal is shown in Table 3.4. Soudal ISOTAET is applied over 12.5 x 12.5 mm (width x depth) in the joint seal of the first layer of gypsum boards. The Soudaseal 211 is applied in a triangular shape (10 x 10 x 14 mm) on both sides (seal 2).

t3.4 Test results seal 2

Test method	Parameter	Sub-criterion	Result in minutes (linear joint seal no.2)
			Thickness flexible wall 100 mm
			Horizontal
EN 1363-1:2020	Integrity (E)	– Cotton pad	120*
EN 1366-4:2021	Integrity (E)	– Sustained flaming > 10 seconds	120*
	Insulation (I)		120*

*The test was finished after 120 minutes in consultation with the client. After finishing the test, the criteria marked with a * where not reached yet.*

Gypsum material and flexible wall (wall thickness 100 mm), vertical

The summary of the test results achieved with gypsum material/flexible wall in a vertical linear joint seal is shown in Table 3.5. Soudal ISOTAET is applied over 12.5 x 12.5 mm (width x depth) in the joint seal of the first layer of gypsum boards (seal 3).

t3.5 Test results seal 3

Test method	Parameter	Sub-criterion	Result in minutes (linear joint seal no.3)	
			Thickness flexible wall 100 mm	
			Vertical	
EN 1363-1:2020	Integrity (E)	- Cotton pad	120*	
EN 1366-4:2021	Integrity (E)	- Sustained flaming > 10 seconds	120*	
		Insulation (I)	115	

The test was finished after 120 minutes in consultation with the client. After finishing the test, the criteria marked with a '' where not reached yet.*

Soudaseal 211 on aerated concrete wall (wall thickness 150 mm) and flexible wall (wall thickness 100 mm), vertical

The summary of the test results achieved with Soudaseal 211 applied on aerated concrete/flexible wall in a vertical linear joint seal is shown in Table 3.6. Soudal ISOTAET is applied over 12.5 x 12.5 mm (width x depth) in the joint seal of the first layer of gypsum boards. The Soudaseal 211 is applied in a triangular shape (10 x 10 x 14 mm) on both sides (seal 4).

t3.6 Test results seal 4

Test method	Parameter	Sub-criterion	Result in minutes (linear joint seal no.4)	
			Thickness aerated concrete wall 150 mm	
			Thickness flexible wall 100 mm	
			Vertical	
EN 1363-1:2020	Integrity (E)	- Cotton pad	120*	
EN 1366-4:2021	Integrity (E)	- Sustained flaming > 10 seconds	120*	
		Insulation (I)	120*	

The test was finished after 120 minutes in consultation with the client. After finishing the test, the criteria marked with a '' where not reached yet.*

Soudaseal 211 on aerated concrete wall (wall thickness 150 mm) and flexible wall (wall thickness 100 mm), horizontal

The summary of the test results achieved with Soudaseal 211 applied on on aerated concrete/flexible wall in a horizontal linear joint seal is shown in Table 3.7. Soudal ISOTAET is applied over 12.5 x 12.5 mm (width x depth) in the joint seal of the first layer of gypsum boards. The Soudaseal 211 is applied in a triangular shape (10 x 10 x14 mm) on both sides (seal 5).

t3.7 Test results seal 5

Test method	Parameter	Sub-criterion	Result in minutes (linear joint seal no.5)	
			Thickness aerated concrete wall 150 mm	Thickness flexible wall 100 mm
			Horizontal	
EN 1363-1:2020	Integrity (E)	– Cotton pad	120*	
EN 1366-4:2021	Integrity (E)	– Sustained flaming > 10 seconds	120*	
	Insulation (I)		120*	

The test was finished after 120 minutes in consultation with the client. After finishing the test, the criteria marked with a '' where not reached yet.*

Aerated concrete wall (wall thickness 150 mm) and flexible wall (wall thickness 100 mm), vertical

The summary of the test results achieved with aerated concrete/flexible wall in a vertical linear joint seal is shown in Table 3.8. Soudal ISOTAET is applied over 12.5 x 12.5 mm (width x depth) in the joint seal of the first layer of gypsum boards (seal 6).

t3.8 Test results seal 6

Test method	Parameter	Sub-criterion	Result in minutes (linear joint seal no.6)	
			Thickness aerated concrete wall 150 mm	Thickness flexible wall 100 mm
			Vertical	
EN 1363-1:2020	Integrity (E)	– Cotton pad	105	
EN 1366-4:2021	Integrity (E)	– Sustained flaming > 10 seconds	105	
	Insulation (I)		60	

4 Classification and field of application

4.1 Reference of classification

This classification has been carried out in accordance with Clause 7 of EN 13501-2:2023 and is valid for the field of application as given in this classification document. The field of application is based on the direct field of application.

4.2 Soudal ISOTAET and Soudaseal 211 joining flexible walls to rigid walls

A linear joint seal made out of Soudal ISOTAET and Soudaseal 211 applied in flexible walls to rigid walls is classified according to the following combinations of performance parameters and classes.

Fire resistance classification	
Applied at both faces	
Rigid wall thickness \geq 150 mm / Flexible wall thickness \geq 100 mm EI 120 – V – X – F – W 0 to 10	Joint depth (mm) 10

E = Criterion integrity, I = Criterion insulation, V = Vertical application in a vertical wall, X = No movement applied, F = Splice applied in the field, W = Permitted width range in millimetres (depth see conditions)

The following conditions apply:

- the classifications are valid for a vertical orientation in a vertical wall, see Figure 4.1;
- the linear joint seals may be applied at both sides to any type of wall of aerated concrete (class G4/600 or heavier), concrete, block work, limestone or masonry with a minimal thickness of 150 mm at one side and a flexible wall with a minimal thickness of 100 mm on the other side. The classification covers flexible walls constructions:
 - with insulation;
 - which are classified for the required fire resistance;
 - with the overall board thickness of minimal 25 mm (each side);
 - with the number of layers of minimal 2 x 12.5 mm (each side);
 - with timber or metal studs.
- the steel (metal stud) profiles are fixed with impact plugs (Fisher N6x60) c.t.c. 333 mm against the rigid wall, the joint is between the gypsum and the rigid wall;
- the Soudal ISOTAET is applied in the joint of the first layer of gypsum boards and rigid wall with a maximum size of 12.5 x 12.5 mm (width x depth);
- the required depth of the sealant may also be increased with respect to the minimum seal depth;
- the classifications are valid for both directions.

f4.1 Wall gypsum to concrete, wall thickness ≥ 100 mm

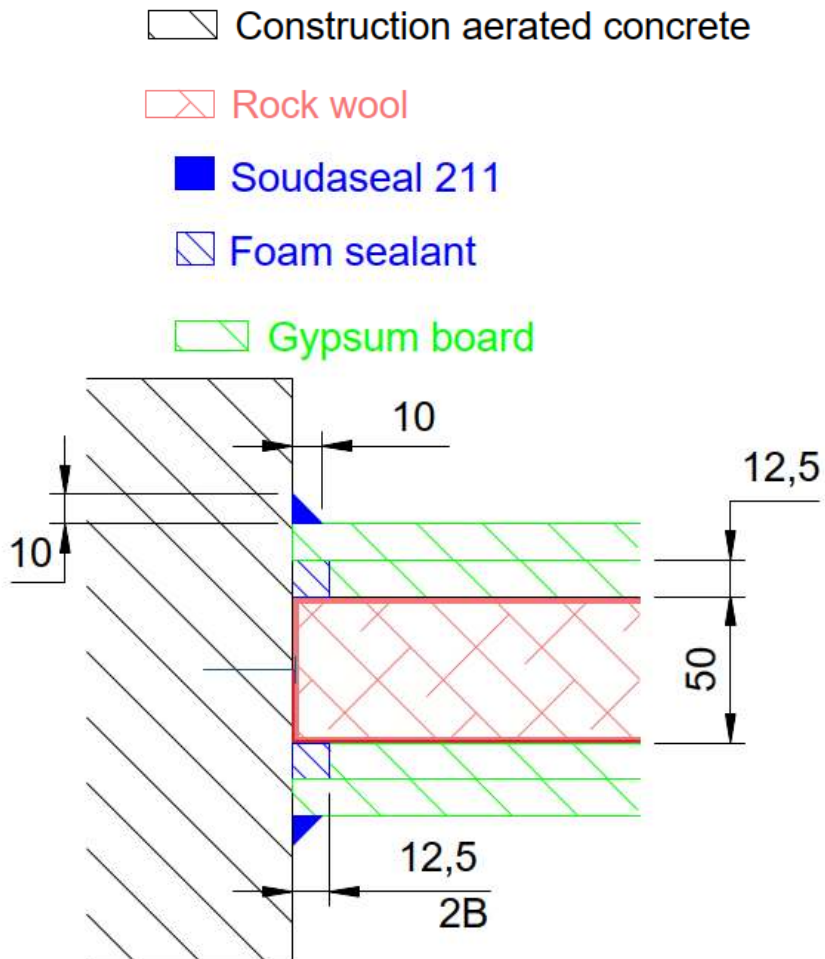

Fire resistance classification	
Applied at both faces	
Rigid wall thickness ≥ 150 mm / Flexible wall thickness ≥ 100 mm EI 120 – T – X – F – W 0 to 10	Joint depth (mm) 10

E = Criterion integrity, I = Criterion insulation, T = Horizontal application in a vertical wall, X = No movement applied, F = Splice applied in the field, W = Permitted width range in millimetres (depth see conditions)

The following conditions apply:

- the classifications are valid for a horizontal orientation in a vertical wall, see Figure 4.2;
- the linear joint seals may be applied at both sides to any type of wall of aerated concrete (class G4/600 or heavier), concrete, block work, limestone or masonry with a minimal thickness of 150 mm at one side and a flexible wall with a minimal thickness of 100 mm on the other side. The classification covers flexible walls constructions:
 - with insulation;
 - which are classified for the required fire resistance;
 - with the overall board thickness of minimal 25 mm (each side);
 - with the number of layers of minimal 2 x 12.5 mm (each side);
 - with timber or metal studs.
- the steel (metal stud) profiles are fixed with impact plugs (Fisher N6x60) c.t.c. 300 mm against the rigid wall, the joint is between the gypsum and the rigid wall;
- the Soudal ISOTAET is applied in the joint of the first layer of gypsum boards and rigid wall with a maximum size of 12.5 x 12.5 mm (width x depth);
- the required depth of the sealant may also be increased with respect to the minimum seal depth;
- the classifications are valid for both directions.

f4.2 Wall gypsum to concrete, wall thickness ≥ 100 mm

 Construction aerated concrete

 Rock wool

 Soudaseal 211

 Foam sealant

 Gypsum board

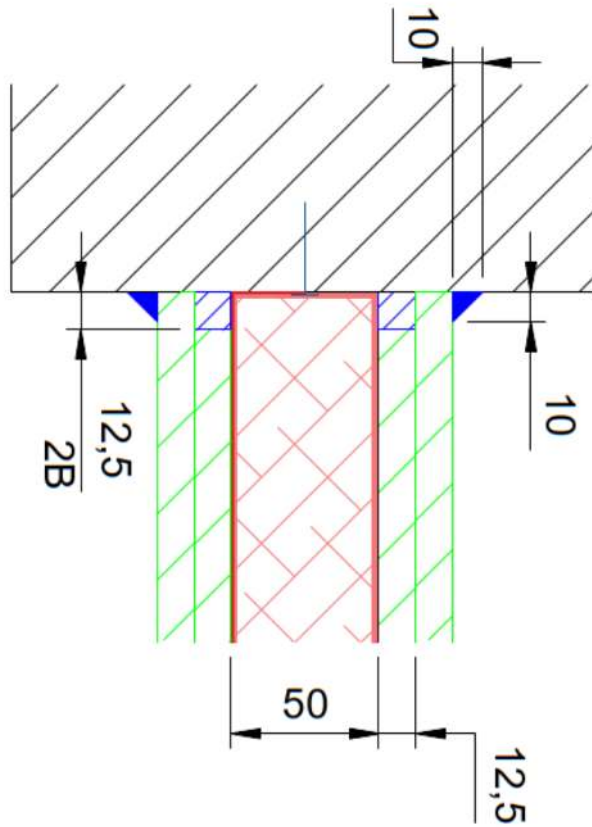

4.3 Soudal ISOTAET joining flexible walls to rigid walls

A linear joint seal made out Soudal ISOTAET applied in flexible walls to rigid walls is classified according to the following combinations of performance parameters and classes.

Fire resistance classification	
Applied at both faces	
Rigid wall thickness ≥ 150 mm / Flexible wall thickness ≥ 100 mm EI 60 - V - X - F - W 0 / E 90 - V - X - F - W 0	Joint depth (mm) 0

E = Criterion integrity, I = Criterion insulation, V = Vertical application in a vertical wall, X = No movement applied, F = Splice applied in the field, W = Permitted width range in millimetres (depth see conditions)

The following conditions apply:

- the classifications are valid for a vertical orientation in a vertical wall, see Figure 4.3;
- the linear joint seals may be applied at both sides to any type of wall of aerated concrete (class G4/600 or heavier), concrete, block work, limestone or masonry with a minimal thickness of 150 mm at one side and a flexible wall with a minimal thickness of 100 mm on the other side. The classification covers flexible walls constructions:
 - with insulation;
 - which are classified for the required fire resistance;
 - with the overall board thickness of minimal 25 mm (each side);
 - with the number of layers of minimal 2 x 12.5 mm (each side);
 - with timber or metal studs.
- the steel (metal stud) profiles are fixed with impact plugs (Fisher N6x60) c.t.c. 333 mm against the rigid wall, the joint is between the gypsum and the rigid wall;
- the Soudal ISOTAET is applied in the joint of the first layer of gypsum boards and rigid wall with a maximum size of 12.5 x 12.5 mm (width x depth);
- the classifications are valid for both directions.

f4.3 Wall gypsum to concrete, wall thickness ≥ 100 mm

 Construction aerated concrete

 Rock wool

 Foam sealant

 Gypsum board

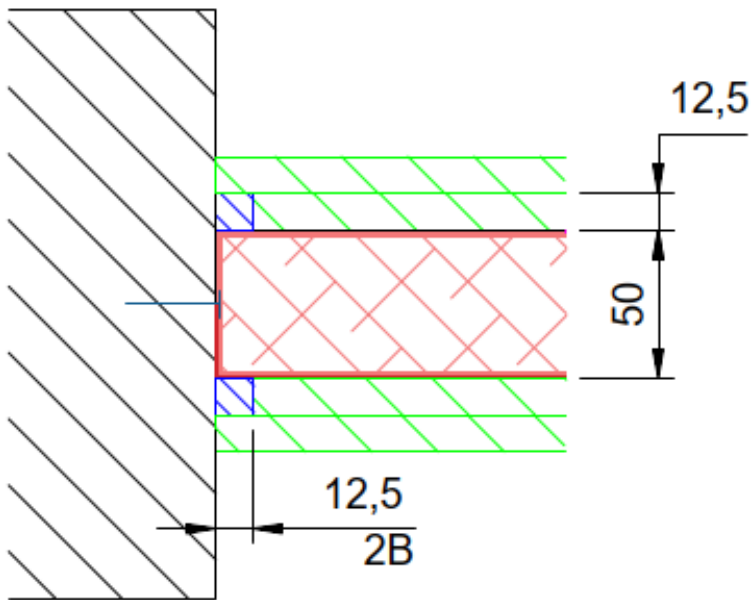

4.4 Soudal ISOTAET and Soudaseal 211 joining flexible walls

A linear joint seal made out Soudal ISOTAET and Soudaseal 211 applied in flexible walls to gypsum is classified according to the following combinations of performance parameters and classes.

Fire resistance classification	
Applied at both faces	
Flexible wall thickness \geq 100 mm EI 120 – V – X – F – W 0 to 10	Joint depth (mm) 10

E = Criterion integrity, I = Criterion insulation, V = Vertical application in a vertical wall, X = No movement applied, F = Splice applied in the field, W = Permitted width range in millimetres (depth see conditions)

The following conditions apply:

- the classifications are valid for a vertical orientation in a vertical wall, see Figure 4.4;
- the linear joint seals may be applied at both sides to gypsum at one side and a flexible wall with a minimal thickness of 100 mm on the other side. The classification covers flexible walls constructions:
 - with insulation;
 - which are classified for the required fire resistance;
 - with the overall board thickness of minimal 25 mm (each side);
 - with the number of layers of minimal 2 x 12.5 mm (each side);
 - with timber or metal studs.
- the steel (metal stud) profiles are fixed against the flexible wall c.t.c. 333 mm, the joint is between the gypsum and the flexible wall;
- the Soudal ISOTAET is applied in the joint of the first layer of gypsum boards and flexible wall with a maximum size of 12.5 x 12.5 mm (width x depth);
- the required depth of the sealant may also be increased with respect to the minimum seal depth;
- the classifications are valid for both directions.

f4.4 Flexible wall to gypsum, wall thickness ≥ 100 mm

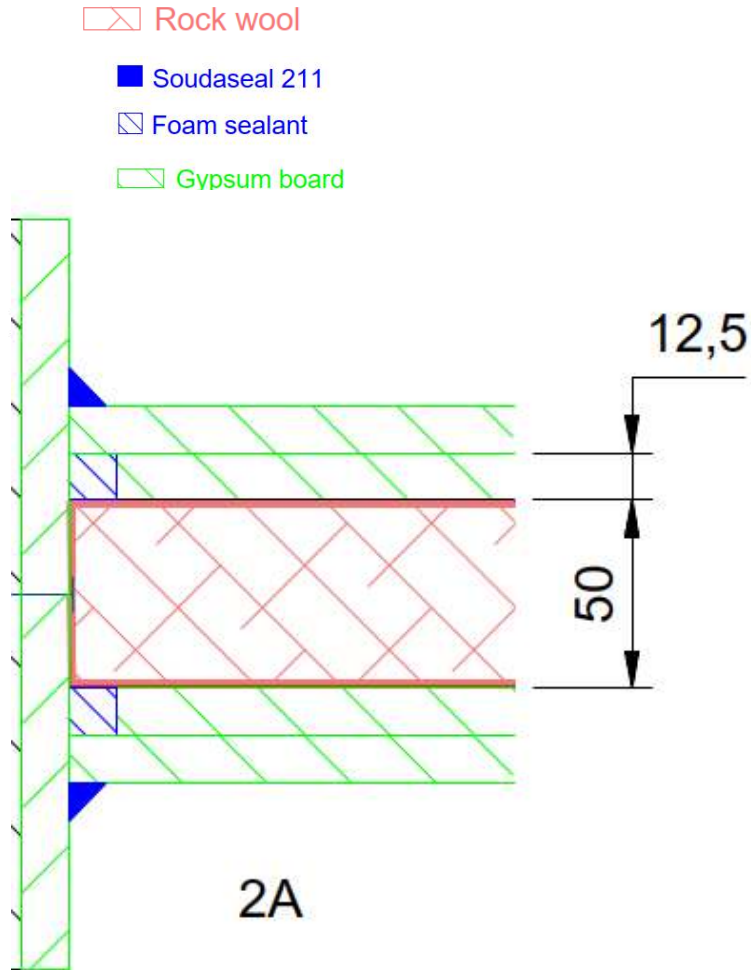

Fire resistance classification	
Applied at both faces	
Flexible wall thickness ≥ 100 mm EI 120 – T – X – F – W 0 to 10	Joint depth (mm) 10

E = Criterion integrity, I = Criterion insulation, T = Horizontal application in a vertical wall, X = No movement applied, F = Splice applied in the field, W = Permitted width range in millimetres (depth see conditions)

The following conditions apply:

- the classifications are valid for a horizontal orientation in a vertical wall, see Figure 4.5;
- the linear joint seals may be applied at both sides to gypsum at one side and a flexible wall with a minimal thickness of 100 mm on the other side. The classification covers flexible walls constructions:
 - with insulation;
 - which are classified for the required fire resistance;
 - with the overall board thickness of minimal 25 mm (each side);
 - with the number of layers of minimal 2 x 12.5 mm (each side);
 - with timber or metal studs.
- the steel (metal stud) profiles are fixed against the flexible wall c.t.c. 300 mm, the joint is between the gypsum and the flexible wall;
- the Soudal ISOTAET is applied in the joint of the first layer of gypsum boards and flexible wall with a maximum size of 12.5 x 12.5 mm (width x depth);
- the required depth of the sealant may also be increased with respect to the minimum seal depth;
- the classifications are valid for both directions.

f4.5 Flexible wall to gypsum, wall thickness ≥ 100 mm

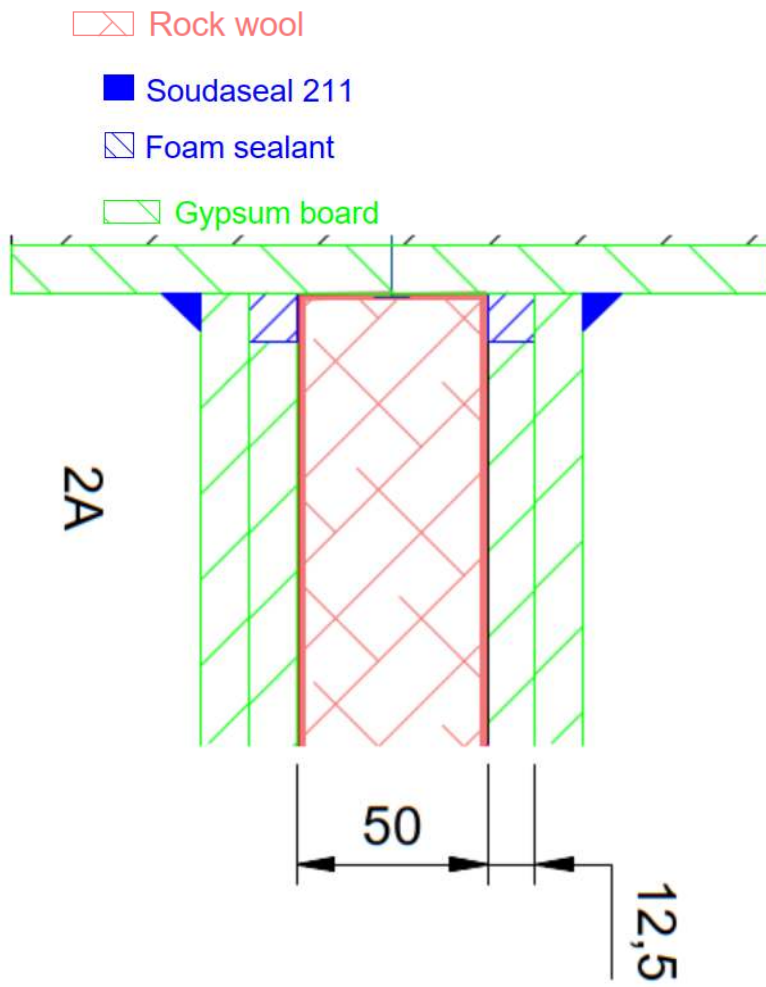

4.5 Soudal ISOTAET joining flexible walls

A linear joint seal made out Soudal ISOTAET applied in flexible walls to gypsum is classified according to the following combinations of performance parameters and classes.

Fire resistance classification	
Applied at both faces	
Flexible wall thickness \geq 100 mm EI 90 – V – X – F – W 0 / E 120 – V – X – F – W 0	Joint depth (mm) 0

E = Criterion integrity, I = Criterion insulation, V = Vertical application in a vertical wall, X = No movement applied, F = Splice applied in the field, W = Permitted width range in millimetres (depth see conditions)

The following conditions apply:

- the classifications are valid for a vertical orientation in a vertical wall, see Figure 4.6;
- the linear joint seals may be applied at both sides to gypsum at one side and a flexible wall with a minimal thickness of 100 mm on the other side. The classification covers flexible walls constructions:
 - with insulation;
 - which are classified for the required fire resistance;
 - with the overall board thickness of minimal 25 mm (each side);
 - with the number of layers of minimal 2 x 12.5 mm (each side);
 - with timber or metal studs.
- the steel (metal stud) profiles are fixed against the flexible wall c.t.c. 333 mm, the joint is between the gypsum and the flexible wall;
- the Soudal ISOTAET is applied in the joint of the first layer of gypsum boards and flexible wall with a maximum size of 12.5 x 12.5 mm (width x depth);
- the classifications are valid for both directions.

f4.6 Flexible wall to gypsum, wall thickness ≥ 100 mm

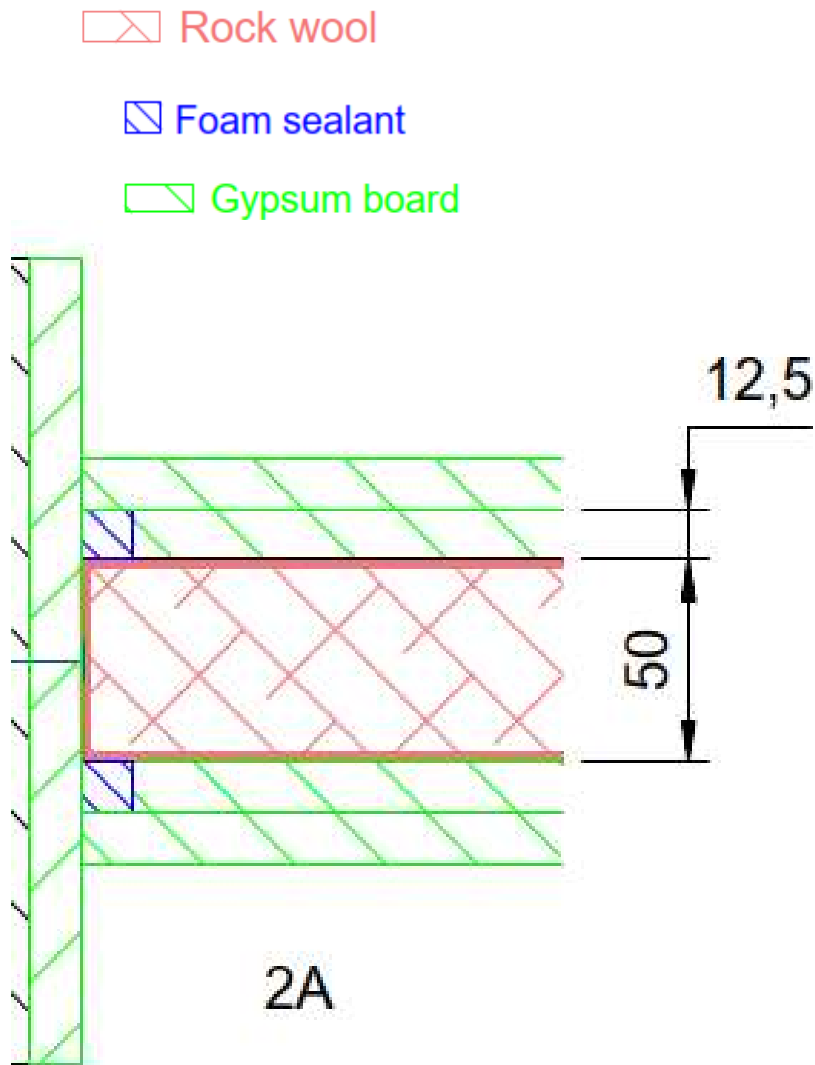

5 Limitations

This classification document does not represent type approval or certification of this product.

Haps,

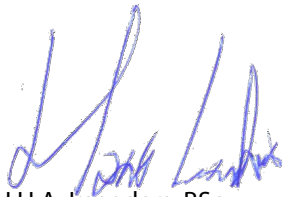

H.H.A. Leenders, BSc.
Head of Laboratory for Fire Safety



D.J. Den Boer, BSc.
Management

This report contains 24 pages